



“Telling Our Stories: Social Studies Education”



Illinois Council for the Social Studies
2025 Spring Conference

April 10, 2025
Eastern Illinois University
Charleston, IL

Welcome to the 2025 ICSS Spring Conference

First, on behalf of the Illinois Council for the Social Studies, I want to thank you for taking the day to engage with social studies education today at our spring conference. This conference gives everyone who attends the opportunity to contribute to the professional dialogue through session presentations and networking with colleagues across Illinois and beyond. Our students need to understand how to navigate and engage in civil dialogue to better address societal concerns. Social Studies teachers today, as in the past, are tasked with exploring the narrative of our histories with our students, however right now this is a volatile task for our educators. What better way to respond to these challenges than for teachers and others to take part in our conference where participants will explore a variety of topics and sessions that are pertinent to social studies students and teachers in the field across grade levels and social studies content areas.

As you move through the sessions, keep in mind that you can be a part of the conference in the future. At ICSS, we are always looking for new and innovative ways to engage with social studies education in the State of Illinois. Look out for our call for proposals for future conferences.

We would also like to encourage you to think about joining the leadership team at ICSS through service on the Executive Board or Board Committees. Our organization depends on great social studies educators in a variety of venues and grade levels giving their time and expertise to continue to grow by bringing resources and support to our members. If you are passionate about supporting such a mission, reach out to the organization and see where you can help.

Once again, Welcome and I hope you enjoy your day.

Theresa Coomer
Conference Program Director
Illinois Council for the Social Studies

Illinois Council for the Social Studies Executive Board Members

President--Andy Levin, Harper College

Vice-President--William Gunn, Lincolnwood High School

Secretary--Jacquelyn Benchik-Osborne, Chicago State University

Treasurer--John Rathbun

Historian-- Megan VanGorder, Governors State University

Region 1 Representative-- Aubrey Southall, Aurora University

Region 2 Representative-- Megan VanGorder, Governors State University

Region 3 Representative-- Vacant

Region 4 Representative--Jay Bickford, Eastern Illinois University

Region 5 Representative--Ryan D'Arcy, Bond County high School

Region 6 Representative-- Brandon West, Altamont Lutheran Interparish

School Member at Large--Lauren Brown, Oak Park

Member at Large--Kathleen Mahoney, Lake View High School

Member at Large--Olivia Leiby

Member at Large--Crystal Johnson, Chicago History Museum

Member at Large--Theresa Coomer, Paw Paw CUSD 271

Executive Director--Dr. Benjamin Wellenreiter, Illinois State University

Registration is at the MLK JR Student Union Park in 9th & Garfield lot (across from Buzzard Hall, see map)

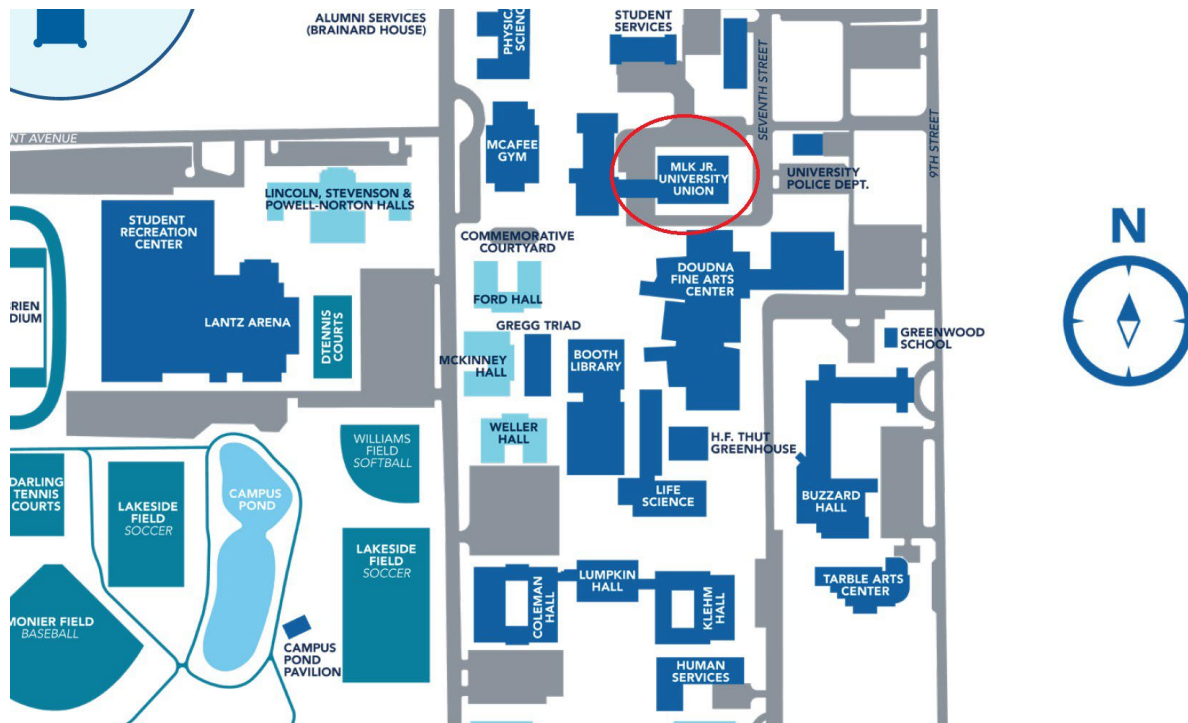

Please **Print out the parking pass** and display it on the dash of your car



UNIVERSITY POLICE DEPARTMENT & PARKING SERVICES

THANKS FOR VISITING EIU!

\$1.50 ONE DAY PARKING PERMIT

DEPARTMENT NAME: IL Council of the Social Studies Conference Participant

VALID DATE: 04/10/2025

Usage Information:

- **Valid for any student or staff lots only.**
- This permit is not valid in Union metered spaces or the Visitor's Lot.
- This permit is only valid during the date listed above.
- Please display this permit on your dashboard in clear view and fully readable from the outside of your vehicle to avoid a citation.

University Police/Parking Services: 217-581-5416

[EIU Campus Parking Map QR Code](#)



Conference Schedule at a Glance

7:30-8:30	Registration and Breakfast Vendors	<p style="text-align: center;">Keynote Speaker</p>  <p style="text-align: center;">Gerald Savage Chief White Winnebago Elder Ho Chunk Nation</p> <p>Gerald's topic A Brief Reintroduction of Native Americans into Illinois is a program sponsored by Illinois Council for Social Studies.</p> <p>Gerald's formal native name is Ho-Chunk Ska Ga (White Winnebago) is a tribal elder with the Ho-Chunk Nation. He will discuss the reintroduction of his family into the Illinois, tribal customs and ways, the history of the Ho-Chunk tribe, modern natives, naming ceremonies, stereotypes, environmental concerns, tribal settlements, reservations and how he got his Chief's bonnet.</p> <p>Gerald's grandparents were Chief Walks with the Wind and Princess Stands on a Cloud. They were very influential in the teaching of Gerald the native customs and ways. He carries on his grandfather's tradition of teaching people about their tribal customs and ways. His program is about the history, past and present, from a Native perspective.</p> <p>Gerald is a Illinois Humanities Road Scholar Speaker, an Illinois America 250 Commissioner, also a low level Bear Clan Chief.</p>
8:30-8:40	Opening Remarks	
8:40-9:30	Keynote Gerald Savage	
9:30-9:40	Break and Vendors	
9:40-10:30	Session 1	
10:30-10:40	Break and Vendors	
10:40-11:30	Session 2	
11:30-12:30	Lunch	
12:30-1:40	Session 3	
1:40-1:50	Break and Vendors	
1:50-2:30	Session 4	
2:30-2:40	Break and Vendors	
2:40-3:30	Session 5	

For session abstracts, go to <https://www.illinoiscss.net/2025-spring-conference-session-information.html> or access QR Code



Guide to Location of Conference Rooms

University Union -- East Wing -- Third Floor

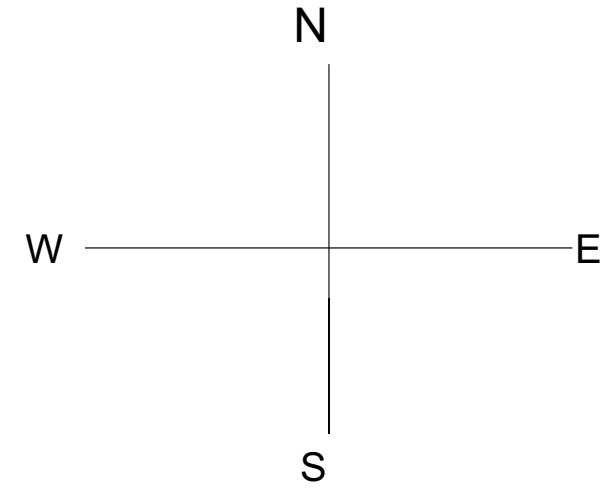

() Denotes Capacity

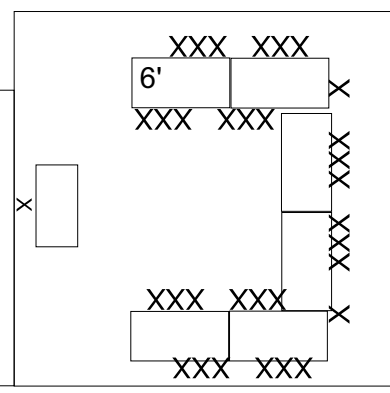
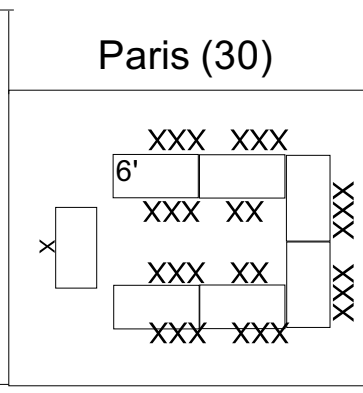
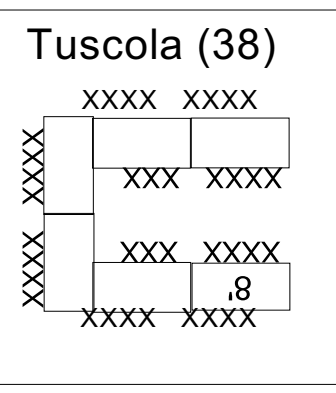
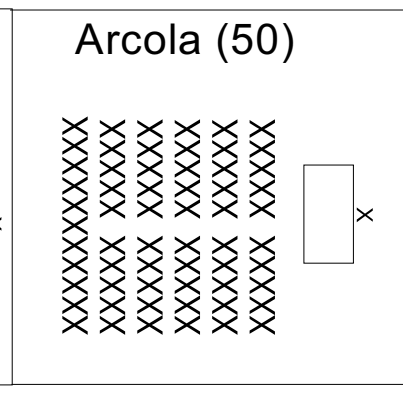
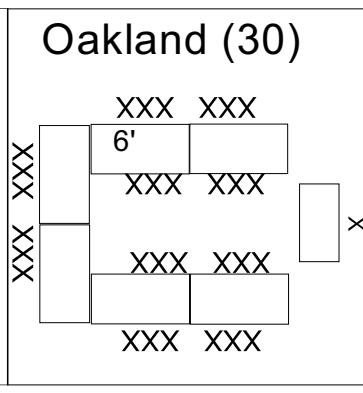
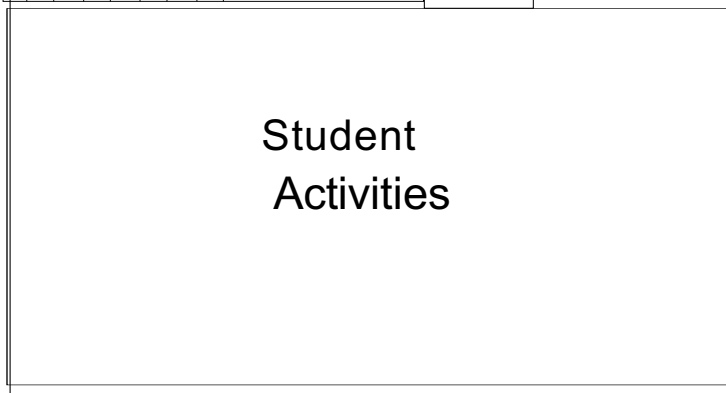
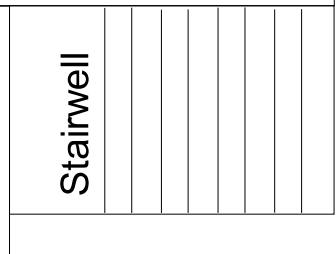
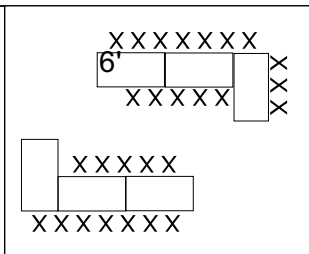
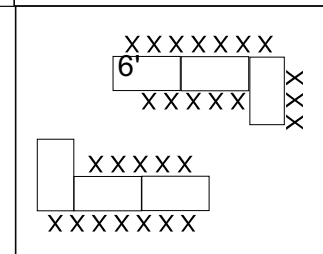
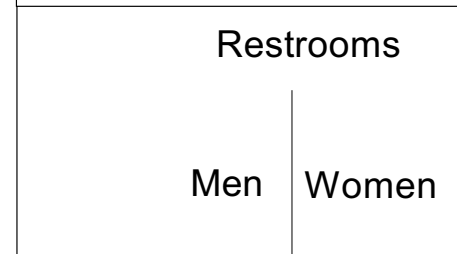
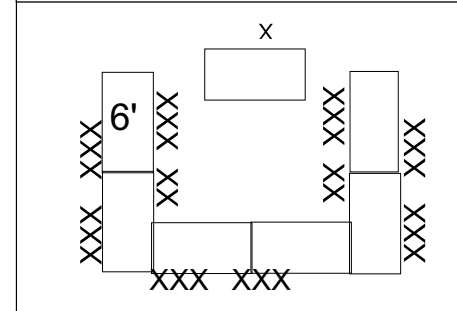
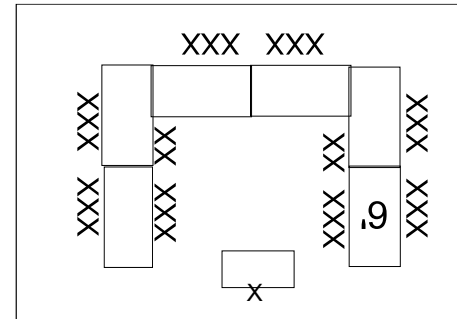
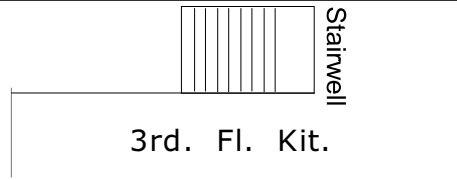
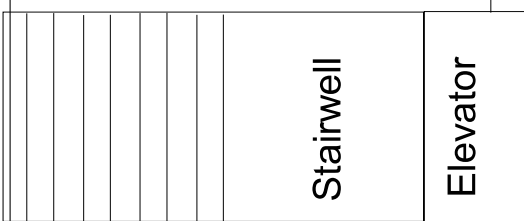
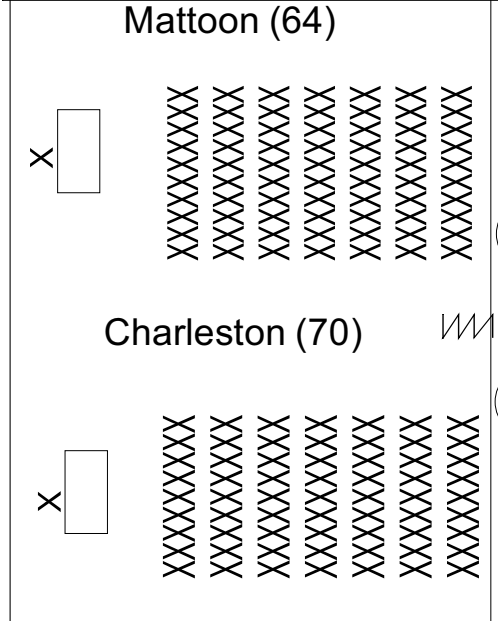
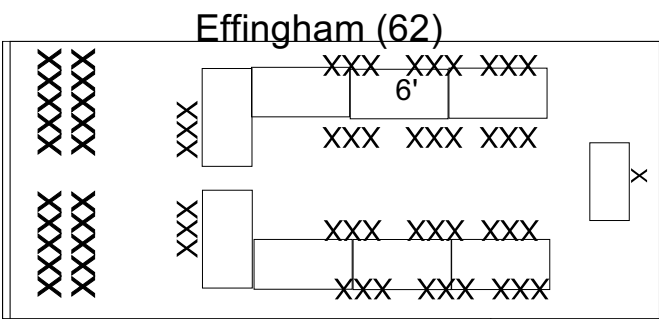

Time	Event	Effingham	Martinsville	Shelbyville	Casey	Greenup
9:40 to 10:30	Session 1	<p>Kassidy Blum</p> <p>The History of a Modern Conflict: Exploring the Arab-Israeli Conflict Through Primary Sources</p> <p>Middle Level, Secondary/High School</p>	<p>Emilee McHorney</p> <p>Unpacking Freedom: Primary Source Analysis with Frederick Douglass</p> <p>Middle Level, Secondary/High School</p>	<p>Julie Eisenband</p> <p>Action Civics in a Multilingual Learner Setting</p> <p>Secondary/High School</p>	<p>Wayde Grinstead</p> <p>Finding the Key: Using Inquiry to Explore the Narratives We Tell</p> <p>Middle Level, Secondary/High School</p>	<p>Tiffany Middleton and Catherine Hawke</p> <p>Legal Precedent Inquiry for these "Unprecedented Times"</p> <p>Secondary/High School</p>
Break and Vendors in Arcola/Tuscola Rooms						
10:30-10:40						
10:40 to 11:30	Session 2	<p>Kassidy Blum</p> <p>Coming to America: The Jewish Immigration Experience (1880-1924)</p> <p>Middle Level, Secondary/High School</p>	<p>Emilee McHorney</p> <p>Framing the Future: Asking Essential Questions About America's Founding</p> <p>Middle Level, Secondary/High School</p>	<p>Lucas Voudrie and Becky Juelfs</p> <p>Telling the Story of History by Incorporating Current Events and Technology</p> <p>Middle Level, Secondary/High School</p>	<p>Noreen Rodríguez, Sohyun An, and Esther Kim</p> <p>TEAACHing Asian America in K-12 Classrooms</p> <p>PreK-12 (general audience)</p>	<p>Tiffany Middleton and Catherine Hawke</p> <p>Native Americans and the U.S. Supreme Court</p> <p>Middle Level, Secondary/High School</p>
11:30 to 12:30	Lunch and Keynote University Ballroom					

Time	Event	Effingham	Martinsville	Shelbyville	Casey	Greenup
12:40 to 1:30	Session 3	<p>Kassidy Blum</p> <p>Religious Literacy in the Social Studies Classroom</p> <p>Elementary, Middle Level, Secondary/High School</p>	<p>Mike Lockett</p> <p>Storytelling – An Effective Tool for Teaching Social Studies</p> <p>PreK-12 (general audience), Early Childhood, Elementary, Middle Level, Special Education</p>	<p>Judith Bock</p> <p>Tell Your Stories Using StoryMaps</p> <p>Middle Level, Secondary/High School</p>	<p>Doug Banwart</p> <p>Teach the History of Sports!</p> <p>Middle Level, Secondary/High School</p>	<p>Kollin Fields and Adam Hill</p> <p>Designing Effective University Curriculum for Social Studies Education Majors</p> <p>Secondary/High School, College and University</p>
1:40 to 2:30	Session 4	<p>Kassidy Blum</p> <p>JEWISH AMERICANS: IDENTITY, HISTORY, AND EXPERIENCE</p> <p>Elementary, Middle Level, Secondary/High School</p>	<p>Regina Aniolowski And Richelle Poisson</p> <p>A Pathway to Participation: Enabling Civic Engagement Through Inquiry for All Learners</p> <p>Elementary, Middle Level, Special Education</p>	<p>Abigail Bussey and Cynthia Klenke</p> <p>Thinking Like a Historian: Getting Hands-on With the Past Through Primary Sources</p> <p>Middle Level, Secondary/High School</p>	<p>Tom Duncanson</p> <p>Our Climate Stories: The Car Line, Jury Nullification. and St. Kitts and Nevis</p> <p>Middle Level, Secondary/High School, Post-secondary, and Social Studies Teacher Education instructors</p>	<p>Angela Terry-Boggs</p> <p>Sparking Curiosity and Engaging Students with Media and Collaboration</p> <p>Middle Level, Secondary/High School</p>

2:30-2:40

Breaks and Vendors in Arcola/Tuscola Rooms

Time	Event	Effingham	Martinsville	Shelbyville	Casey	Greenup
2:40 to 3:30	Session 5	<p>Jessie Gillooly</p> <p>Building Multiperspectivity with Culturally Inclusive Primary Documents</p> <p>Middle Level, Secondary/High School</p>	<p>Laurie Pasler and Dave Fript</p> <p>From Nuremberg to Now: Teaching the Story of WWII</p> <p>Middle Level, Secondary/High School</p>	<p>Razak Dwomoh and Boatemaa Tawiah-Sarpong</p> <p>The Branches of Government: Pre-service Teachers' Experiences of Supreme Court Oral Arguments</p> <p>PreK-12 (general audience)</p>	<p>Bonnie Laughlin-Schultz</p> <p>Disrupting the Traditional Antislavery Narrative and Engaging Students in Visual Analysis</p> <p>Middle Level, Secondary/High School, preservice teachers</p>	<p>Andrea Fields and Jessica Toran</p> <p>Beyond the Census: Finding Diverse Stories in Your Local Community</p> <p>Elementary, Middle Level, Secondary/High School</p>